

James Walker®

JWSMS Mechanical Seal

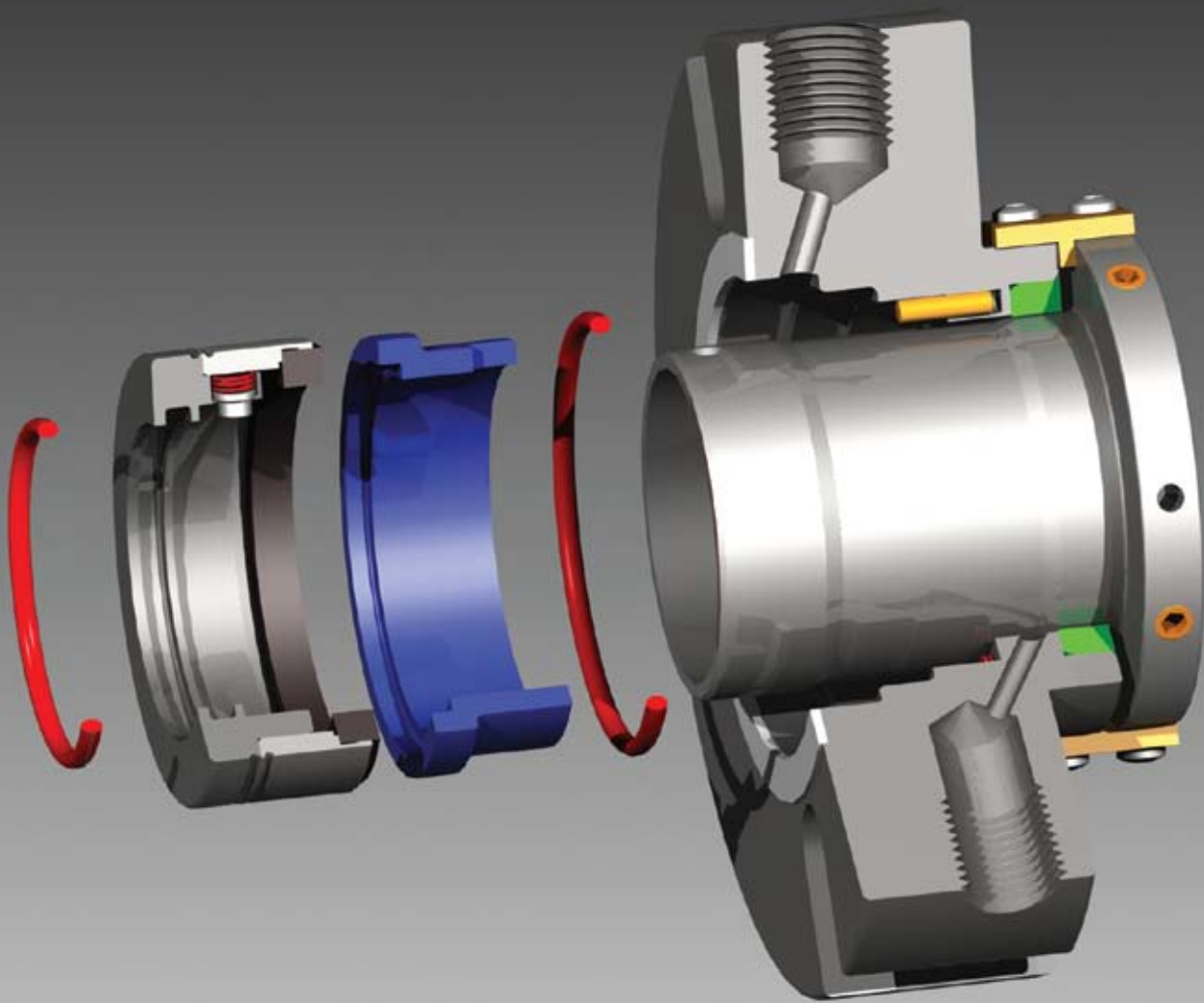

High Performance Sealing Technology



High performance sealing technology

Contents

Page
2 Introduction
3 Design features
4 Operational features
5 Operational features
6 Seal layout
7 Dimensions & materials
8 Contact details

Over 125 years of sealing

In 1882, Scottish engineer James Walker founded a company to sell engineering accessories to ships in the Port of London. He soon developed Lion® Brand High Pressure Steam Packing, to enhance the performance and safety of marine equipment, and followed this with Golden Walkerrite® high pressure jointing. Together, these products proved vital to the success of the new generation of high efficiency steam engines that powered mankind into the 20th century.

Prior to his development work, few other companies had applied engineering science to the design and manufacture of gland packings or jointings. James Walker's success with the products set the company that bears his name on the route to worldwide prominence and started a new technology — high performance fluid sealing.

Today, the company is a global supplier of high integrity fluid sealing products to virtually every industrial sector. This demands an international manufacturing base, plus highly efficient sales and distribution operations.

James Walker's worldwide family of companies has over 50 production, engineering, distribution and customer support sites spread across Europe, Australasia, Asia Pacific, Africa and the Americas. Highly developed IT networks, e-commerce systems and logistics operations link all the sites and give customers in over 100 countries the surety of supply they need.

Sealing specialists

From sites in Holland, Belgium and France, James Walker supplies both static and dynamic seals, as well as maintenance services and custom-manufactured elastomeric products.

Our comprehensive ranges of sealing products offer significant value-in-service and efficiency benefits to plant operators and manufacturers.

Ongoing developments in the process industry have increased substantially the demand for long-life custom-designed products. Our consultancy and design department — combining research, design, development and manufacturing — will create sound sealing solutions to meet your specific needs.

Professional advice

Great personal involvement is a central value at James Walker. This is why we provide you with soundly based advice. From the simplest to the most complex application, every different sealing problem receives individual attention. This ensures every sealing arrangement we recommend will meet your expectations.

Extensive service

James Walker also specialises in the expert refurbishment of all types and makes of pumps, accessories, pilot valves and mechanical seals.

We offer quick delivery and service with a team on stand-by for you 24 hours a day. When you have an emergency, you can rely on us for immediate assistance and technical support.



Stocks of James Walker products are held worldwide for immediate despatch.

Trademark & patent acknowledgements

James Walker acknowledges the following trademarks and patents mentioned in this document:

Aflas®
Hastelloy®
Plunger lock drive pin

Asahi Glass
Hayes International Inc
Flex-A-Seal, patent pending

General information

Health warning: If PTFE or fluoroelastomer (eg, FKM, FFKM, FEPM) products are heated to elevated temperatures, fumes will be produced which may give unpleasant effects, if inhaled. Whilst some fumes are emitted below 250°C from fluoroelastomers or below 300°C from PTFE, the effect at these temperatures is negligible. Care should be taken to avoid contaminating tobacco with particles of PTFE or fluoroelastomer, or with PTFE dispersion, which may remain on hands or clothing. Material Safety Data Sheets (MSDS) are available on request.

Information in this publication and otherwise supplied to users is based on our general experience and is given in good faith, but because of factors which are outside our knowledge and control and affect the use of products, no warranty is given or is to be implied with respect to such information. Specifications are subject to change without notice. Statements of operating limits quoted in this publication are not an indication that these values can be applied simultaneously.

Design features

Design philosophy — reduced maintenance costs

At James Walker we believe that good design is the route to reducing plant maintenance costs. That is why, in collaboration with Flex-A-Seal, we have based the design of JWSMS on our knowledge and experience of many types and makes of mechanical seals, and to meet the precise needs of the engineers who are responsible for the reliability, operation and maintenance of your rotary plant.

This approach makes JWSMS the best value solution for your rotary pumps and mixers when plant reliability, health and safety issues, and total owning costs are of paramount importance.

Our JWSMS compact cartridge mechanical seal fits most DIN and ANSI pumps, to ensure it is suitable for a very wide variety of applications worldwide.

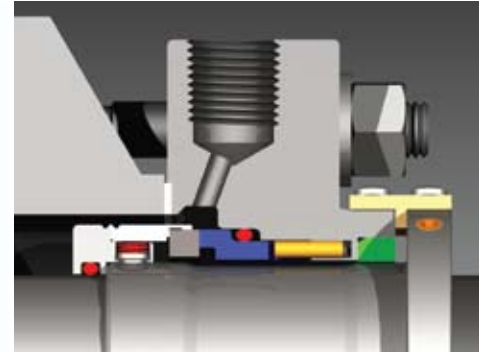

Features of JWSMS compact single cartridge seal

Modular design for different duties

Because of its modular design, with all interchangeable parts available in various materials, the JWSMS mechanical seal is applicable to many different process applications and fluid media.

Pre-assembled

This seal is designed for simple assembly and swift installation. It is supplied pre-assembled, with all components correctly aligned and adjusted for a longer and trouble-free working life.

**Hydraulic double balanced**

With its hydraulic double balanced stationary element, the JWSMS works efficiently at higher pressure, higher vacuum and higher speeds than most other designs.

Self-aligning

When the mating faces start to wear within your JWSMS, the stationary sealing face re-adjusts to a clean and wear-free area, maintaining contact pressure on the working surface and avoiding hang-up problems with the dynamic 'O' ring.

Stationary coil springs

The multiple coil springs are stationary and divorced from the fluid media being handled. This prevents them becoming clogged with slurry and crystallising products. As the springs are stationary they are capable of better alignment when the seal is operating with shafts that are misaligned.

Robust drive pins

Our robust drive pins readily withstand the high forces created during starts and stops.

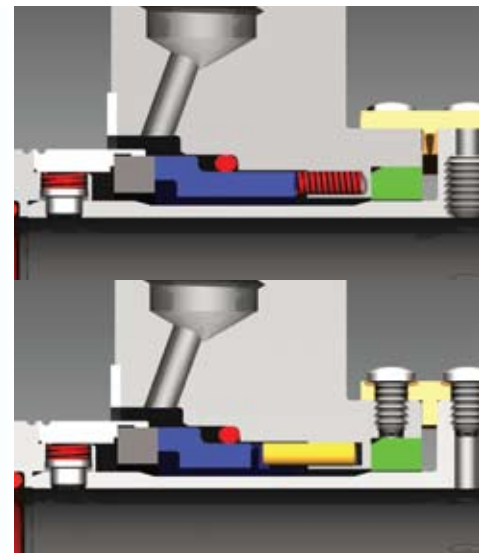
**Optimised working surface geometry**

The geometry of the running faces has been fine tuned using FEA (finite element analysis) software to ensure that high integrity sealing is maintained at high pressures and when subjected to severe vibration. Although surface deformation caused by excessive temperatures and pressures cannot be eliminated, the lubrication film between the working faces will be retained in the majority of cases.

It is this level of design dedication that ensures that our JWSMS mechanical seal resists the problems created by shaft misalignment, vibration, high speeds, high pressures and high vacuum.

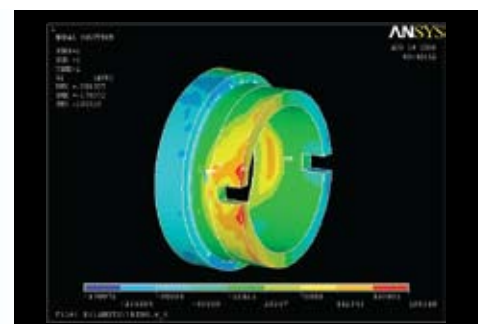

Operational features

Plunger lock drive pin

On JWSMS, we have replaced traditional cup-tipped set screws with a unique plunger lock drive pin from Flex-A-Seal. This extremely robust fixing can handle five times the torque load of the usual set screw arrangement featured on most other mechanical seals.

But, more importantly, it facilitates quick, easy assembly and significantly simplifies refurbishment when using our replacement seal kit.

The plunger lock drive pin is divorced from the fluid media being handled, and our JWSMS uses one less 'O' ring than mechanical seals that rely on set-screw based arrangements.

Our plunger lock drive pin system also eliminates the possibility of sleeve distortion caused by over tightened set screws. Moreover, there is no risk of set screws becoming loose and causing catastrophic seal failure.

Our unique plunger lock drive pin (near right) is much stronger and gives a far more accurate location than the traditional set screw arrangement (far right).

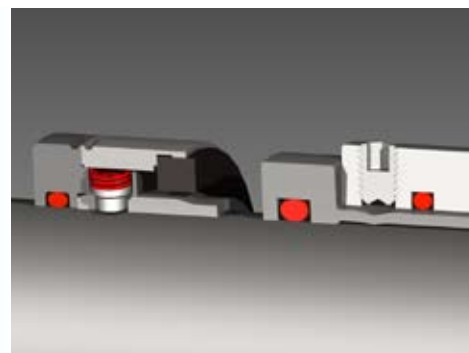

The plunger lock drive pin system provides for very simple installation, with positive location, and needs no special tools for fitting.

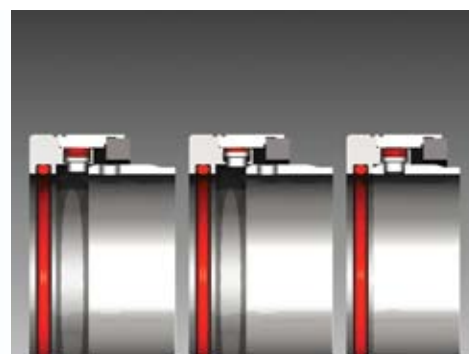

The two main wearing surfaces can be replaced with ease. This minimises the chance of seal failure.

Customers can readily refurbish the seal on site using our seal replacement kit.

Our JWSMS cartridge mechanical seal requires only two 'O' rings. This saves costs and increases the reliability of the seal, as there are fewer components that need replacement.

The 'O' ring groove design complies with FDA 3A. It is suitable for food and pharmaceutical processing duties.

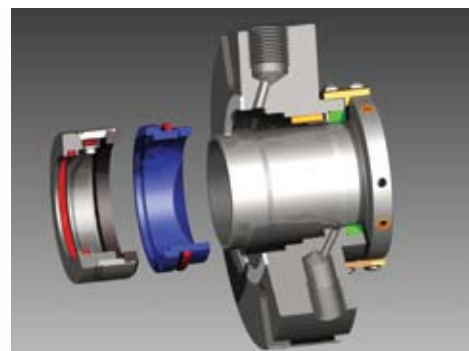

Operational features

Large flushing space

The large flushing space within JWSMS ensures efficient cooling, cleaning and lubrication of the seal faces. It also reduces fluid turbulence and the erosion of components within the cartridge unit.

Heat dissipation with hot fluid media

The seal's improved cooling, flushing and lubrication capabilities prove of great value when handling abrasive slurries and hot fluid media. Increased flushing space within the cartridge provides a more stable temperature at the working faces and improves heat dissipation from the rotating element.

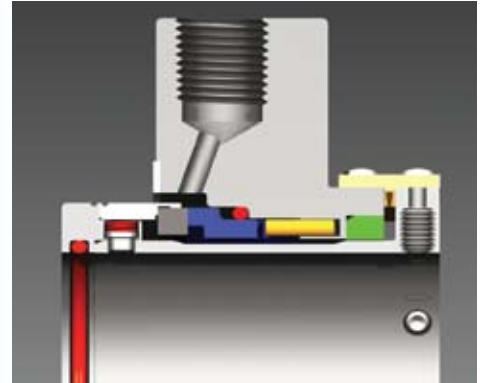

Quench and vent

The quench and vent connection allows steam, liquids or grease to be applied under pressure to the sealing unit to prepare it for new applications. This proves of particular value when your JWSMS has previously been used with slurry or crystallising media.

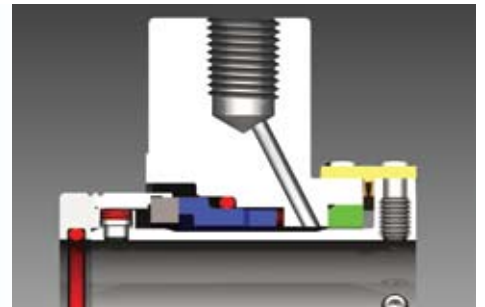

Efficient setting and fixing

Our system of setting and fixing plates and fastenings ensure that the cartridge unit sits concentrically and perpendicular on the pump shaft. This significantly improves the efficient working life of the seal.

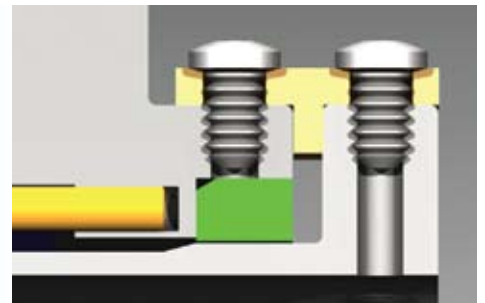

Non-clog stationary springs

Our multiple spring design provides an evenly distributed load on the sealing faces. This helps to maintain the lubrication film — even under misalignment conditions.

The springs cannot become clogged with fluid media as they are divorced from the product flow. This is of particular value in food processing applications and with crystallising media.

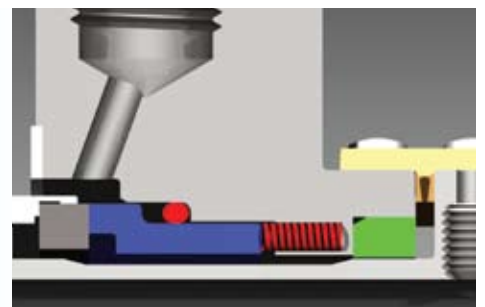

Throttle bushing

This throttle bush arrangement prevents fluid media from spraying out of the cartridge unit. Instead, any leakage is kept within the cartridge and safely transferred via a vent/drain system to a collection sump — which is of particular value when hot or aggressive media is being handled.

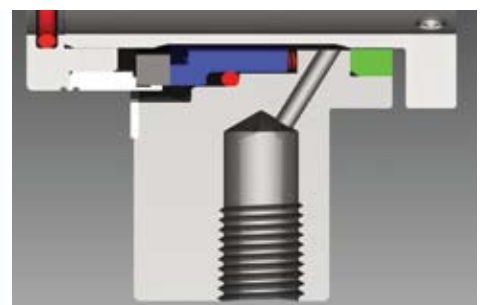

Seal layout

Feature benefits

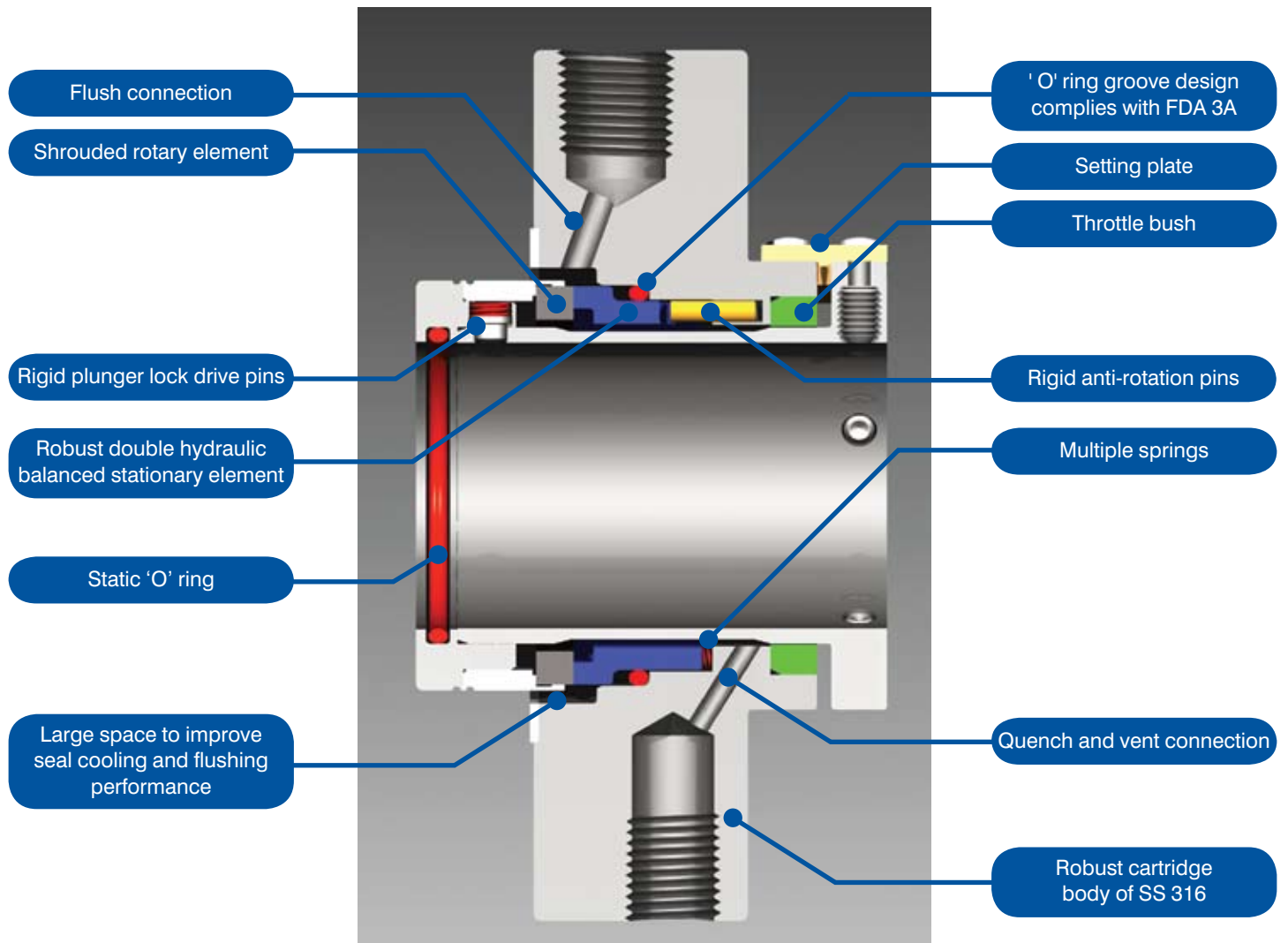

Typical applications

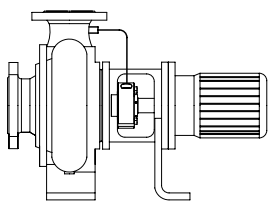

HORIZONTAL PUMPS

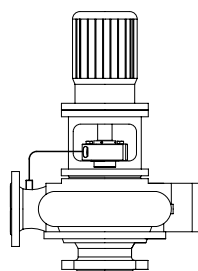

VERTICAL PUMPS

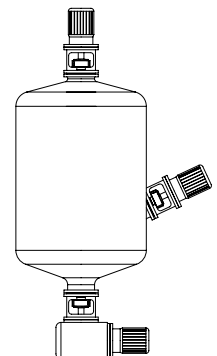

MIXERS

Dimensions & materials

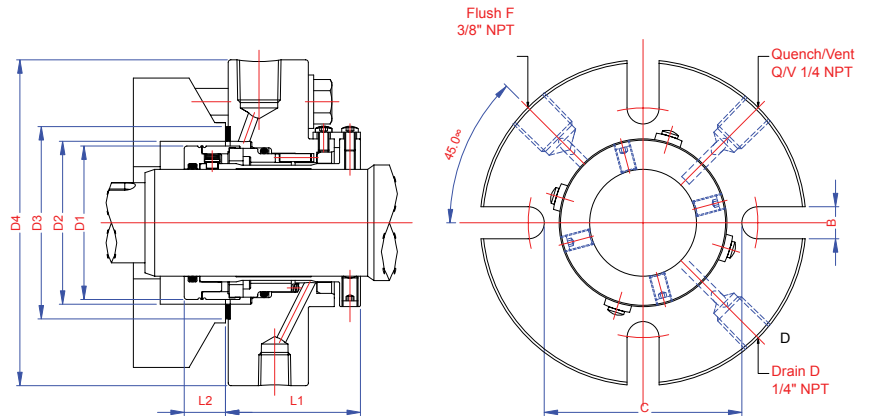
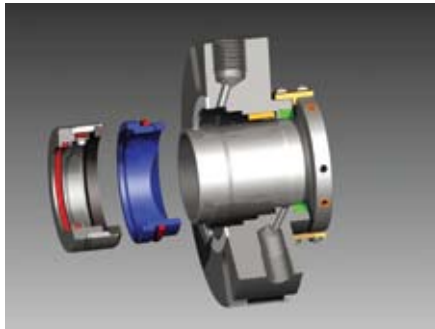

Material codes							Shaft size		D1	D2		D3	D4	L1	L2	C	B	FL NPT	Q&V NPT
							inch	mm		min mm	max mm								
070	JWSMS	A	Q	V	M	G	1.000	25	43.2	45	48	56.6	108.0	50.8	20.2	62	12.7	3/8"	1/4"
Shaft size							1.125	28	43.2	45	49	59.8	108.0	50.8	20.2	70	12.7	3/8"	1/4"
Seal type							1.250	30	49.5	51	55	63.0	108.0	50.8	20.2	64	12.7	3/8"	1/4"
Material rotary face								32	49.5	51	58	63.0	108.0	50.8	20.2	70	12.7	3/8"	1/4"
Material stationary face							1.375	33	49.5	51	58	66.2	114.3	50.8	20.2	70	12.7	3/8"	1/4"
Seal face material- code definition								35	49.5	51	60	66.2	114.3	50.8	20.2	70	12.7	3/8"	1/4"
A	Carbon/ antimony						1.500	38	55.9	58	63	72.5	127.0	50.8	20.2	75	12.7	3/8"	1/4"
B	Resin carbon						1.625	40	59	60	65	75.9	127.0	50.8	20.2	77	14.3	3/8"	1/4"
Q	Silicon carbide self-sintered						1.750	43	62.2	64	68	78.9	139.7	50.8	20.2	80	14.3	3/8"	1/4"
Q1	Silicon carbide reaction-bonded							45	62.2	65	70	78.9	139.7	50.8	20.2	80	14.3	3/8"	1/4"
Q2	Silicon carbide/ graphite						1.875	48	65.4	68	73	82.0	139.7	50.8	20.2	85	14.3	3/8"	1/4"
O	Ceramic						2.000	50	68.6	70	75	83.6	146.1	50.8	20.2	87	14.3	3/8"	1/4"
S	Chrome steel 1.4136						2.125	53	71.7	73	83	91.6	152.4	50.8	20.2	97	17.5	3/8"	1/4"
U	Tungsten carbide/ cobalt						2.250	55	74.9	76	85	91.6	152.4	50.8	20.2	94.2	17.5	3/8"	1/4"
U1	Tungsten carbide/ nickel						2.375	60	81.2	85	90	97.9	158.8	52.1	20.2	102	17.5	3/8"	1/4"
'O' rings and gasket							2.500	63	84.3	88	93	97.9	165.1	52.1	20.2	106	17.5	3/8"	1/4"
A	Aflas®						2.625	65	90.4	92	95	103.4	165.1	52.1	20.2	109	17.5	3/8"	1/4"
E	Ethylene-propylene						2.750	70	92.7	95	104	109.7	177.8	52.1	20.2	118	17.5	3/8"	1/4"
K	Perfluoroelastomer						3.000	75	99.1	104	109	119.4	190.5	54.0	20.2	129	17.5	3/8"	1/4"
P	Nitrile elastomer						3.250	80	106	109	114	125.7	196.8	54.0	21.4	135	17.5	3/8"	1/4"
S	Silicone elastomer						3.375	85	109.2	114	119	128.9	196.8	54.0	21.4	139	20.6	3/8"	1/4"
V	Fluoroelastomer						3.625	90	115.7	119	124	135.3	203.2	54.0	21.4	145	20.6	3/8"	1/4"
T	PTFE						3.750	95	118.9	124	129	138.4	209.5	54.0	21.4	148	20.6	3/8"	1/4"
T1	FEP						4.000	100	130.8	129	134	151.1	222.3	54.3	21.4	154	20.6	3/8"	1/4"
Springs																			
Metal parts																			
	Metal codes																		
G	SS 316																		
M	Hastelloy® C276																		

Other James Walker companies worldwide

James Walker & Co

Tel: +44 (0)1270 536000
Fax: +44 (0)1270 536100
Email: csc@jameswalker.biz

James Walker Australia

Tel: +61 (0)2 9644 9755
Fax: +61 (0)2 9645 2009
Email: jwadmin@jameswalker.com.au

James Walker China

Tel: +86 21 6876 9351
Fax: +86 21 6876 9352
Email: info.cn@jameswalker.biz

James Walker Deutschland

Tel: +49 (0)40 386 0810
Fax: +49 (0)40 389 3230
Email: info@jameswalker.de

James Walker Iberica

Tel: +34 94 447 0099
Fax: +34 94 447 1077
Email: iberica@jameswalker.biz

James Walker Benelux BV

James Walker Benelux BV
Röntgenstraat 7-9-11
3261 LK Oud-Beijerland
The Netherlands
Tel: +31 186 633111
Fax +31 186 633110
E: info.oudbeijerland.nl@jameswalker.biz

Meeleweg 40

7711 EN Nieuwleusen
The Netherlands
Tel: +31 529 484283
Fax +31 529 484268
E: info.nieuwleusen.nl@jameswalker.biz

James Walker Ireland

Tel: +353 (0)21 432 3626
Fax: +353 (0)21 432 3623
Email: sales.ie@jameswalker.biz

James Walker Italiana

Tel: +39 02 257 8308
Fax: +39 02 263 00487
Email: jameswalker@jameswalker.it

James Walker Mfg (USA)

Tel: +1 708 754 4020
Fax: +1 708 754 4058
Email: sales.jwvmfg.us@jameswalker.biz

James Walker New Zealand

Tel: +64 (0)9 272 1599
Fax: +64 (0)9 272 3061
Email: sales@jameswalker.co.nz

James Walker Norge

Tel: +47 22 706800
Fax: +47 22 706801
Email: firmapost@jameswalker.no

James Walker Benelux NV

Mechanicalaan 14-16
BE-2610 Wilrijk (Antwerp)
Belgium
Tel: +32 38207900
Fax +32 38285484
E: sales.jwa.be@jameswalker.biz

Walderdonk 63BE-9185

Wachtebeke
Belgium
Tel: +32 93457615
Fax: +32 93455866
E: sales.jwg.be@jameswalker.biz

Rue des Scabieuses 12

BE-5100 Naninne
Belgium
Tel: +32 81257070
Fax +32 81401323
E: sales.jwn.be@jameswalker.biz

James Walker Oil & Gas (USA)

Tel: +1 281 875 0002
Fax: +1 281 875 0188
Email: oilandgas@jameswalker.biz

James Walker Singapore

Tel: +65 6777 9896
Fax: +65 6777 6102
Email: sales@jameswalker.com.sg

James Walker South Africa

Tel: +27 (0)31 205 6251/2/3
Fax: +27 (0)31 205 6266
Email: info.za@jameswalker.biz

James Walker France

Head Office
Z. I. Le Tronchon BP 36
17 Rue Jean-Elysée Dupuy
69542 Champagne Cedex
France
Tel: + 33 (0)437 49 74 80
Fax: + 33 (0)437 49 74 83
E: headoffice.fr@jameswalker.biz

Lyon & Nantes: telephone as Head Office

E: sales.lyon.fr@jameswalker.biz
E: sales.nantes.fr@jameswalker.biz

Dunkirk

Tel: +33 (0)328 58 05 80
E: sales.dunkerque.fr@jameswalker.biz

Metz

Tel: +33 (0)387 73 75 49
E: sales.metz.fr@jameswalker.biz

Marseille

Tel: +33 (0)442 77 68 90
E: sales.marseilles.fr@jameswalker.biz

James Walker Développement

(Mechanical seal reconditioning)
Tel: +33 (0)437 49 74 80
E: sales.jwdeveloppement.fr@jameswalker.biz