

James Walker®

Tidal & Wave Energy

Issue 1



- **Over 100 years of experience in marine and subsea applications**
- **A range of proven, class-leading technologies**
- **Partnering with OEMs to drive development of new concepts**
- **Reducing maintenance requirements by optimising design**

High Performance Sealing Technology



Respected reputation

Over a century of experience

James Walker has been in the business of fluid sealing and control for over 125 years. From our earliest products we have had close associations with the marine industry and throughout our history the company has developed sealing solutions and components in parallel with advances in marine propulsion and offshore technology.

As a result, we have amassed specialised knowledge across a broad range of marine applications and issues.



Worldwide distribution

Our role as a global supplier demands an international manufacturing base, plus highly efficient sales and distribution operations. We have a worldwide family of companies with over 50 production, engineering, distribution and customer support sites spread across Europe, Australasia, Asia Pacific, Africa and the Americas.

At the local level, a close-knit network of James Walker companies and official distributors works in partnership with customers in well over 100 countries.

Marine specialists

James Walker products are globally recognised by engineers for their quality and reliability. These are assets the James Walker name and Lion logo have fostered in the marine industry since the 1880s when our Scottish engineer founder, Mr James Walker, introduced his innovative packing for high-efficiency steam engines.

Since those early days, our products have increased beyond recognition in range and technical excellence to match the complex and demanding applications of today's plant and equipment.

Today, we manufacture and supply a highly diverse range of fluid sealing items and other specialised products to the world's commercial and naval fleets, shipyards, oil companies, energy producers and original equipment manufacturers in every industrial market.

Over 125 years of marine industry experience

Delivering quality

Quality design, quality manufacture and quality service are paramount throughout our worldwide operations. We start with the best raw materials and use advanced manufacturing techniques with strict quality control.

This culture is reinforced by top-level technical, sales and logistics support to ensure a total quality service to every customer.



A history of innovation

Driving development

Our position as a technology leader, in combination with the vast experience of our applications engineering and materials science teams, helps us to identify and supply the most appropriate and competitive solution for each individual customer's requirement.

We run a structured development programme for each of the industrial markets served by the business, working in partnership with customers to identify the current and future needs to be addressed, and to improve key performance parameters such as cost effectiveness, longevity, safety and environmental care.



James Walker in-house test facilities provide accurate simulation of actual operating conditions

**... a highly structured product development process
focused on cost-effective solutions that complement
customers' operational demands**

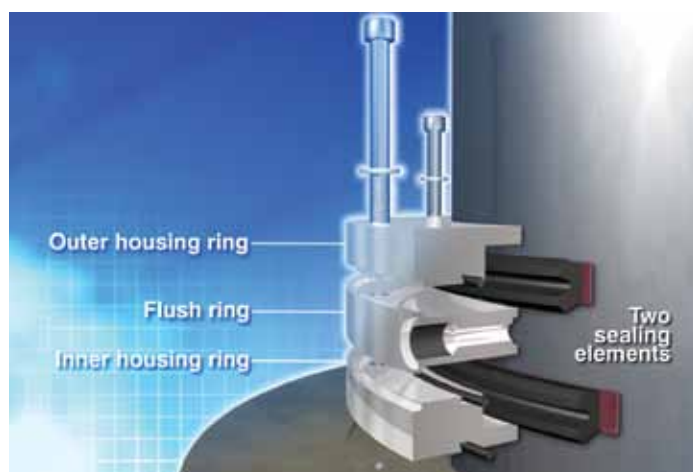

James Walker's HydroSele® cartridge has fast become one of the leading solutions for Francis turbine main shaft sealing

Proving performance

Working in close co-operation with customers, industry bodies and academic institutions, our facilities provide some of the most advanced test regimes outside of actual operational application. This gives our customers the confidence that James Walker products have been fully tested to meet the required conditions.

With our broad range of engineering resources and expertise we design and build custom test-rigs for many of the projects we undertake. In addition, and central to our research and development programmes, the James Walker Technology Centre houses the core of our world-class test facilities.

Tailored solutions

Enabling advances

Our vast ranges of fluid sealing products and associated components are widely used across the full spectrum of renewable energy applications. The quality and longevity of our products are well appreciated by OEMs and operators, underwriting equipment reliability and helping to minimise plant downtime.

We have a specific strategic focus towards the renewable energy industry and are actively developing dedicated technical resources for the research and testing of seal designs and components for renewable energy applications.

James Walker products are found in critical applications at the forefront of key global industries ensuring that processes run safely and smoothly, day after day.

Growing together

Many advances in industries such as renewable energy, marine propulsion and subsea oil exploration have been made possible by materials, seal design and bolting technology pioneered by James Walker.

By applying our collective knowledge and engineering experience we are now able to support the development of concepts in the emerging Tidal and Wave Energy industry, working in partnership with entrepreneurial engineers to help their concepts become a commercial generating reality.

Bespoke solutions

Backed by in-house testing and manufacturing to world-class standards, James Walker brings practical expertise and leading-edge technology to the custom-design of optimum solutions that match our customers' exact requirements.

Bespoke doesn't necessarily mean expensive however. At James Walker our aim is to create the most cost-effective solution and we focus carefully on optimising the lifetime cost of ownership. In the majority of cases we work in partnership with our customers, jointly developing solutions in close co-operation with their own engineering teams.

Working together at the early concept stage

The most effective solutions are those developed through early collaboration, where our engineering teams are able to contribute ideas and advice that will provide inbuilt reliability and performance in the finished project.

Many of the products and solutions provided by James Walker may be of a relatively low financial cost when compared to the overall cost of a tidal or wave energy project, but their impact on the performance and reliability of such a project can be huge. Consultation at the earliest stage is therefore highly advantageous and will often provide cost savings later in the project.

Early involvement of our applications engineering teams can eliminate many potential operational problems at the design stage

Extreme environments

Customer specific design

We carry a global reputation for solving sealing problems backed by testing and manufacturing to world-class standards. Our custom design operation is led by the James Walker Technology Centre engineering teams who carry many years' experience of working closely with engineers from every sector of industry plus a fundamental understanding of all types of equipment that need fluid sealing components.

FEA (finite element analysis) techniques are used for modelling seal designs and fine tuning different aspects, such as lip geometry and materials specification, to obtain the required performance.

These developments then move to prototypes that can be fully tested on a suite of static and dynamic test rigs to simulate, as closely as possible, the anticipated operating conditions.

Successes on high-profile development projects produce very positive feed back. The resulting improvements achieved in seal performance — in terms of operational life, sealing integrity, and the ability to work under extreme conditions — are greatly appreciated by James Walker customers on a worldwide basis.

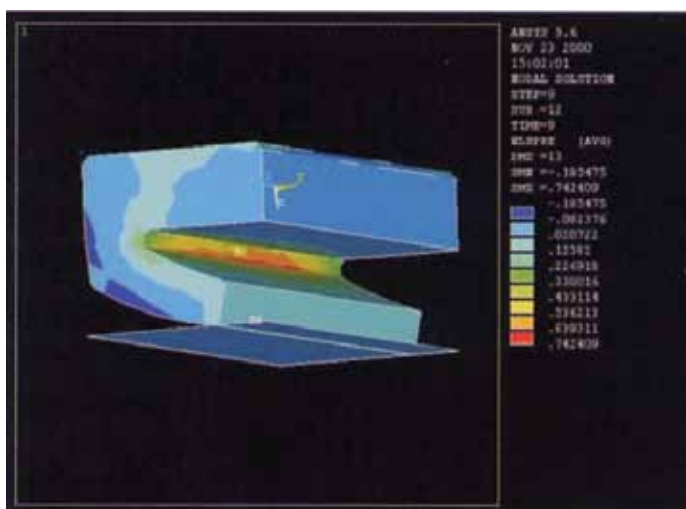

Extreme environments

Our capabilities in high performance materials science are relied upon worldwide by customers who need top quality materials that are validated and proven to operate:



- At extremes of pressure
- In chemically aggressive and physically abrasive environments
- Under rapid gas decompression (RGD) conditions
- To the highest safety and performance specifications laid down by international bodies
- At extremes of temperature
- Where failure could have significant health & safety, environmental or financial risk
- In food, pharmaceutical and bioprocessing applications where contamination prevention is critical to the process

Materials development

In-house capability and investment

We are constantly reviewing the performance of our elastomers, polymers and plastics and seeking to develop new compounds and variants that will address the operational problems faced by our clients and the industry sectors we serve.

Across industries as diverse as aerospace, power generation and bioprocessing, James Walker's technical ability and expertise has helped create what are now recognised as class-leading, best practice products and solutions.

API
Norsok M-710
Shell
Total
BS EN ISO 9001
BS EN 9100
BAE Systems
Ministry of Defence
FDA
USP Class VI

...working to the highest standards and audited by industry's most exacting businesses.

Continual investment in the latest manufacturing techniques, testing facilities and materials processing equipment ensures that James Walker maintains a leading role in materials development.

With full control over material formulation, compounding and production, the company is in the best possible position to ensure the consistent quality and performance of the finished product.

Specially formulated for...

James Walker materials currently lead the world in critical applications across a broad range of industries. Our developments are often targeted at specific performance criteria such as...

...Long life

Extending the time between maintenance is a key target for many industries. James Walker long-life materials have helped push maintenance intervals further than ever before in wind turbine, marine propulsion and steel rolling mill applications.

...Pressure

For more than 40 years, James Walker's leading-edge development of rapid gas decompression (RGD) resistant



elastomers has made a significant contribution to the successful exploitation of oil and gas reserves in increasingly hostile environments.

The James Walker Technology Centre incorporates a world-leading Rapid Gas Decompression testing facility.

...Low friction

Combining specially formulated compounds and innovative seal design, James Walker provides effective sealing with minimal frictional power loss for a range of power generation and marine propulsion rotary applications.

Advanced engineering

...Clean environments

James Walker is one of very few sealing manufacturers with full class 10,000 clean-room manufacturing and inspection facilities.

For over 30 years we have applied our expertise in specialised elastomers to the biopharmaceutical sector and developed elastomer-based sealing materials for the food, beverage and semiconductor industries for 20 years.



Materials capable of tackling the toughest applications

James Walker Devlon® thermoplastic materials are amongst the toughest and hardest wearing available. Produced by monomer casting and extrusion, they provide a comprehensive range of wear resistance, impact strength and toughness with almost limitless application potential.

It is our innovative use of additives, such as plasticisers, lubricants and heat stabilisers that differentiates Devlon from the competition. By varying the volume of components and additives in the mix, our technologists produce materials with specific properties to suit the requirements of each customer application.

Significant material advantages include:

- **lower cost**
- **zero corrosion**
- **low friction**
- **resistant to shock loading**
- **significantly improved lifespan**
- **exceptional resistance to wear**
- **does not support marine growth**

Condition monitoring & maintenance reduction

As processes and equipment become increasingly automated and installations are placed in remote or hostile environments, James Walker is working with partners in a number of industries to develop condition monitoring concepts that will improve operational safety and enable better scheduling of maintenance.

Cartridge systems with multiple, sequentially deployable sealing elements permit seals to be changed within seconds when leakage occurs or reaches unacceptable levels.

KlickFix® sequentially deployable sealing system

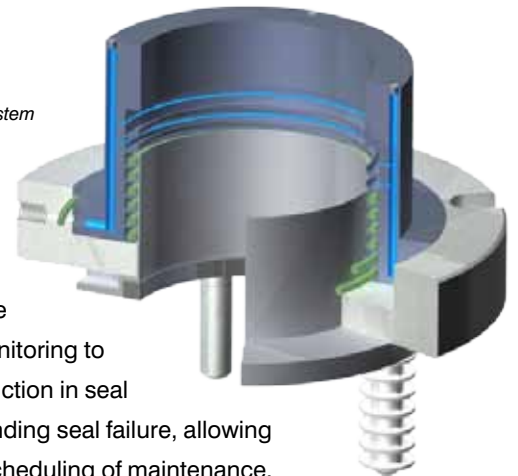

Seal performance and lubricant monitoring to help identify reduction in seal integrity or impending seal failure, allowing more accurate scheduling of maintenance.



Further development of RotaBolt® bolt tension and monitoring technology to automatically transmit a warning of any loss of bolt tension.

Leading technology

Turning the tide for tidal turbine power

Some of the world's first commercially viable tidal power generation schemes are protected by James Walker sealing products. Working with tidal and wave scheme developers our seals have been designed into, and specified for, a wide range of applications including horizontal and vertical axis turbines, oscillating and pressure differential schemes plus Venturi-effect turbines.



The prototype SeaGen turbine was installed in Strangford Lough during May 2008 and is the first tidal current or wave energy system in the world to have exceeded 1,000 hours of operation delivering more than 800MWh into the National Grid.

Two 1100mm diameter Walkersele® lip seals fitted back to back protect the main bearings from seawater ingress and prevent pollution of the environment by stopping lubricant seepage into the sea. These have already worked maintenance-free for over three years.



SeaGen in Strangford Lough with its rotors raised

On-site seal joining for reduced downtime and maintenance costs

Developed in conjunction with customer maintenance engineers, the Walkersele® OSJ-2 system offers seal replacement without the need for disassembly, specialist services or equipment.

The resulting seal is no short-term fix, but a permanent seal with the same performance levels and continuity as the original endless version fitted by OEMs.



- Simple, rapid fitting – no specialised skills required
- Cuts fitting costs and downtime
- Fully moulded endless-seal performance with split-seal assembly convenience
- Available for shaft sizes from 60mm to over 2000mm

Walkersele OSJ-2 is widely used in the hydropower and marine industries around the globe on critical applications such as propeller shaft and turbine blade root sealing.

The beauty of this product lies in its simplicity – after just a few hours' hands-on training, a maintenance fitter is able to produce a securely bonded joint that provides a split Walkersele with the integrity of a fully moulded endless seal.

Leading technology

Custom cartridge units

James Walker custom designed cartridge solutions are already specified by a UK tidal technology manufacturer. This sealing system, in combination with a pressurised lubrication system, is designed to deal with high varying pressures that are experienced when the device is deployed and operating on the seabed.

The cartridge unit is a development of the highly successful James Walker HydroSele® cartridge which has been proven over the last fifteen years in a wide range of hydropower turbine applications. This product is now widely regarded by hydropower engineers and turbine OEMs as one of the best sealing options for Francis turbines.

Designed for longevity, James Walker cartridge units are compact and simple to install. When the integral sealing elements do eventually require replacing, this is a simple task thanks to the split design of both the cartridge and sealing elements, which means generating units are off-line for the minimum amount of time.



Thermoplastic housings

The latest James Walker cartridge designs explore the use of thermoplastic materials for the cartridge itself, further reducing the weight of the unit for easier handling. The use of thermoplastics also plays an important part in producing a highly competitive and cost-effective sealing option and extending life, particularly in a marine environment.

Long-life, high performance hydraulic sealing

James Walker hydraulic sealing solutions are employed across a variety of critical heavy-duty marine applications including vessel stabiliser units, hydro turbine blade root seals, dam gates and barrage actuators



Over 20 year life for James Walker hydraulic seals on Thames Barrier

James Walker supplies custom sealing products for heavy-duty and extreme applications to OEMs and end users of hydraulic cylinders covering the fundamental requirements of:

Rod/gland seals: to seal around the emerging rod or ram.

Piston seals: to seal around the piston used to generate motive force.

Wipers, scrapers and protector bellows: where the ingress of external contaminants must be eliminated.

Bearing strips: where insufficient provision has been made to support lateral loads.

From control actuators right up to the heaviest cylinders, our hydraulic seals have been specifically developed to offer:

- Optimum equipment performance
- Reduced leakage
- Low friction operation
- Long trouble-free operating life

These products are also exceptionally well proven in less demanding roles, where their superior quality provides *best value* benefits in terms of improved reliability plus reduced equipment downtime and maintenance costs.

Leading technology

Revolutionary bolting technology

Many critical bolted joints can often be extremely difficult to access for bolt replacement, tightening or even checking – this is particularly the case in subsea applications.

In these instances, RotaBolt® fasteners not only guarantee initial installation to the correct tension, they also provide a simple tactile check that the correct tension is being maintained.

For bolts without easy access for a tactile check, RotaBolt Vision – with its bold yellow indicator line – is ideal.

The indicator can be seen from up to 25m away and is often used on subsea and seabed applications in the oil and gas industry where it allows bolt tightness checks to be carried out by camera equipped ROVs.



RotaBolt® provides significant improvements in safety and reliability without any requirement for specialised technical expertise

Prevention of mechanical and structural failure

Bolting and accurate tension control – both at installation and during operational life – are critical to the performance, safety and longevity of any structure or installation.

The joints of tidal and wave power generators are subject to substantial structural, fatigue and transverse vibration loadings which installed bolt tension/joint compression has to resist.

Any weakness in this area can easily translate into equipment malfunction or even a catastrophic failure.

RotaBolt tension control technology has already been adopted in key industries such as wind power and offshore oil & gas to help;

- Reduce construction times
- Minimise maintenance costs
- Improve equipment performance
- Increase operational safety
- Extend maintenance schedules

RotaBolt achieves all this without the need for specialised equipment, training or personnel.

Thermoplastic component innovation

James Walker engineers are not afraid to challenge convention. Leveraging the inherent strengths and properties of thermoplastic materials, our engineers seek to replace and improve upon the performance levels of existing components manufactured in materials including bronze, brass, hardened steel, laminates and incorrectly specified low performance plastics.



Leading technology



Working with one of the leading wave power technology developers to supply bespoke plastic parts, the James Walker design and plastic manufacturing capability has created a successful tailored solution that satisfied the customer's needs and initiated further projects aimed at improving the longevity of other equipment parts.

Replacing heavy expensive metallic components with lightweight, resilient engineering plastics provides a significant operational and cost benefits

James Walker has complete control of the manufacturing process, from casting of the material through to finished machined components. Using the most modern CNC equipment housed in a customised manufacturing set-up, we can machine individually tailored products on both small and large scales.

Our facilities can produce anything from a single bespoke item machined out of solid billet to millions of injection moulded components, all with the back-up of 3D design, finite element analysis (FEA) and rapid prototyping facilities.

Component protection and operational safety

Originally designed to protect studs and gaskets on flange joints from the atmospheric corrosion encountered in locations such as chemical plants, offshore platforms, ships, paper mills and underground pipelines, the principal behind James Walker flange protectors has been transferred to other applications and is ideal for a number of duties in tidal and wave energy.



Similar protection is offered by moulded elastomer bellows and bolt caps – all products offered by James Walker to help extend component life and reduce maintenance time and cost.



Protection offered by James Walker also extends to the safety of personnel working on and around installations through our leading range of non-slip flooring materials, currently specified across the oil and gas, marine, and offshore wind sectors.

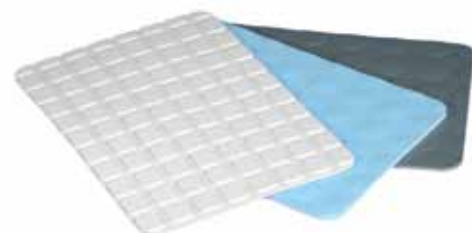

James Walker worldwide support and distribution

James Walker & Co

Tel: +44 (0)1270 536000
Fax: +44 (0)1270 536100
Email: csc@jameswalker.biz

James Walker Asia Pacific

Tel: +65 6777 9896
Fax: +65 6777 6102
Email: sales.sg@jameswalker.biz

James Walker Australia

Tel: +61 (0)2 9721 9500
Fax: +61 (0)2 9721 9580
Email: sales.au@jameswalker.biz

James Walker Benelux (Belgium)

Tel: +32 3 820 7900
Fax: +32 3 828 5484
Email: sales.be@jameswalker.biz

(Netherlands)

Tel: +31 (0)186 633111
Fax: +31 (0)186 633110
Email: sales.nl@jameswalker.biz

James Walker Brasil

Tel: +55 21 2220 2152
Fax: +55 21 2531 1704
Email: sales.br@jameswalker.biz

James Walker China

Tel: +86 21 6876 9351
Fax: +86 21 6876 9352
Email: sales.cn@jameswalker.biz

James Walker Deutschland

Tel: +49 (0)40 386 0810
Fax: +49 (0)40 389 3230
Email: sales.de@jameswalker.biz

James Walker France

Tel: +33 (0)437 497 480
Fax: +33 (0)437 497 483
Email: sales.fr@jameswalker.biz

James Walker Iberica

Tel: +34 94 447 0099
Fax: +34 94 447 1077
Email: sales.es@jameswalker.biz

James Walker Ireland

Tel: +353 (0)21 432 3626
Fax: +353 (0)21 432 3623
Email: sales.ie@jameswalker.biz

James Walker Italiana

Tel: +39 02 257 8308
Fax: +39 02 263 00487
Email: sales.it@jameswalker.biz

James Walker Mfg (USA)

Tel: +1 708 754 4020
Fax: +1 708 754 4058
Email: sales.jwvmfg.us@jameswalker.biz

James Walker New Zealand

Tel: +64 (0)9 272 1599
Fax: +64 (0)9 272 3061
Email: sales.nz@jameswalker.biz

James Walker Norge

Tel: +47 22 706800
Fax: +47 22 706801
Email: sales.no@jameswalker.biz

James Walker Oil & Gas (USA)

Tel: +1 281 875 0002
Fax: +1 281 875 0188
Email: oilandgas@jameswalker.biz

James Walker South Africa

Tel: +27 (0)31 304 0770
Fax: +27 (0)31 304 0791
Email: sales.za@jameswalker.biz

General information

Information in this publication and otherwise supplied to users is based on our general experience and is given in good faith, but because of factors which are outside our knowledge and control and affect the use of products, no warranty is given or is to be implied with respect to such information. Unless governed by type approval or contract, specifications are subject to change without notice. Statements of operating limits quoted in this publication are not an indication that these values can be applied simultaneously. Material Safety Data Sheets (MSDS) are available on request.

To ensure you are working with the very latest product specifications, please consult the relevant section of the James Walker website: www.jameswalker.biz.

Environmental statement: This brochure is manufactured using advanced environmentally friendly technologies and follows the strict environmental standard BS EN ISO 14001. Made from chlorine-free pulp (ECF) with post-consumer recycled fibre obtained from sustainable wood forests, and printed using vegetable-based inks, by Binfield Printers Ltd. For those who wish to reduce further their impact on the environment, this publication is also available as a PDF from: www.jameswalker.biz

James Walker & Co Ltd

Renewable Energy Support Team
1 Millennium Gate, Westmere Drive
Crewe, Cheshire CW1 6AY, UK
Tel: +44 (0)1270 536000
Fax: +44 (0)1270 536100
Email: powergen.jwc.uk@jameswalker.biz

www.jameswalker.biz



CERTIFICATE No. FM 01269
BS EN 9100:2003
BS EN ISO 9001:2008